

# Analysing the applicability of the heat balance method for estimating sap flow in boreal forest conditions

Martti Perämäki<sup>1)</sup>, Timo Vesala<sup>2)</sup> and Eero Nikinmaa<sup>1)</sup>

<sup>1)</sup> *Department of Forest Ecology, P.O. Box 24, FIN-00014 University of Helsinki, Finland*

<sup>2)</sup> *Department of Physics, P.O. Box 9, FIN-00014 University of Helsinki, Finland*

Perämäki, M., Vesala, T. & Nikinmaa, E. 2001. Analysing the applicability of the heat balance method for estimating sap flow in boreal forest conditions. *Boreal Env. Res.* 6: 29–43. ISSN 1239-6095

A simple quasistationary dynamic model was constructed to analyse the performance of the stem heat balance method for estimating sap flow in tree stems. Model predictions were compared with field measurements of sap flow in a 35-year-old dominant Scots pine tree and in a smaller understorey mountain ash. The sap flow was measured with the Dynamax Flow32™ Stem-Flow Gauge system. Results indicate that the heat balance method underestimates the sap flow in steady-state conditions, especially with stems of larger diameters. The reason for the underestimate of the flow in the case of bigger stems is the inaccurate estimation of sap temperature increase  $\Delta T$  when measured on the surface of the stem. Additionally, the difference between air and sap temperatures, which is typical of boreal conditions in the early summer mornings, may cause substantial peaks in the sap flow estimates. Increasing the power input will decrease the latter problem but this may result in problems with overheating of the stem.

## Introduction

Transpiration of trees can be measured directly from the leaves by enclosing them in a chamber and analysing the resulting water vapour concentration changes while the chamber is closed (e.g. Hari *et al.* 1999). Transpiration can also be estimated indirectly by analysing tree sap flow (e.g. Hinckley *et al.* 1994). The stand level evapotranspiration can be measured by using the

eddy covariance technique (e.g. Rannik 1998). The methods that monitor sap flow are superior to the direct gas exchange measurements in that they do not alter the leaf environment and therefore are able to give less biased estimations of transpiration, provided that they estimate sap flow correctly (Hinckley *et al.* 1994). The relative ease of use, affordable instruments and the unbiased estimation of transpiration by whole trees have increased the preference of this meth-

od in comparison with direct gas exchange measurements for transpiration estimation.

Sap flow rate has been analysed using either heat, deuterium or some other substances such as dyes as flow tracers (Dugas *et al.* 1992, Nikinmaa *et al.* 1997). The small diurnal changes in xylem diameter caused by the fluctuating water tension has also been shown to reflect the water flow in stem (Irvine and Grace 1997, Sevanto *et al.* 2001). Heat-based methods are the most commonly used methods for sap flow estimations due to their relative simplicity of use and the fairly affordable measuring system. Methods based on either velocity of a heat pulse (Jones *et al.* 1988), temperature profiles (Grani-er 1985), or heat balance of a constantly heated woody segments (Sakuratani 1981, Dynamax 1990) have also been used. Some applications warm the exterior of the measured stem segment and follow the variation in the segment surface temperatures (Dynamax 1990), whereas in others, the heating element and the temperature sensors are inserted into a stem segment (Cermak *et al.* 1976). The heat balance method with constant heating gives direct flow estimates based on the monitoring results; thus there is no need for calibration (Valancogne and Nasr 1989).

The stem heat balance method (SHB) has been criticized for giving erroneous results in certain conditions (Grime and Sinclair 1999). Numerical analyses and field results suggest that these may be attributed to changes that exceed the time response of the system, changes in the heat storage in the wood and variation in the temperature field within the studied stem segment (Valancogne and Nasr 1989, Baker and Nieber 1989, Groot and King 1992, Grime and Sinclair 1999).

Using the stem heat balance system (SHB), we analysed the stem sap flow of various-sized woody segments from different tree species in boreal forest conditions in southern Finland between 1996 and 1999. When measuring stem segments larger than 50 mm in diameter, particularly during early summer, we frequently observed erroneous behaviour in the sap flow estimates resembling the results reported by Grime *et al.* (1995a), and Grime and Sinclair (1999). To analyse the measurements and to study the possibilities for correcting the prob-

lems in the measurements, we designed a simple dynamic model of heat and mass transfer in tree segments that simulates both the stem segment heat balance and the measurements with SHB-gauges wrapped around the stem (Dynamax 1990).

The aim of this article is to analyse how the segment size, power input and variation in the sap flow depth in the stem, all of which are relevant questions for sap flow measurements in conifers, influence the accuracy of the SHB-method. We particularly emphasize the numerical analyses of relatively large stems, since they have not been extensively analysed in the literature. We used an axisymmetric, quasistationary stem heat-flux model to study the conditions under which the method gives acceptable estimations for the flow. Firstly, the influence of stem size and flow rate on the accuracy of the flow estimate is studied with numerical experiments. The model is then used to simulate observed sap-flow measurements with the SHB-method, and finally, the applicability of this method for sap-flow estimations is discussed.

## Theoretical background

### Description of the stem heat flux model

The general heat transport equation for combined conduction and convection ( $Q_{c_w}$ ) in a stem segment can be written as (e.g. Groot and King 1992):

$$\rho c \frac{\partial T}{\partial t} = \frac{1}{r} \left[ k_r \frac{\partial T}{r} \left( r \frac{\partial T}{\partial r} \right) \right] + k_z \frac{\partial^2 T}{\partial z^2} - Q_{c_w} \frac{\partial T}{\partial z} + P \quad (1)$$

where  $r$  is the density of the stem,  $c$  is the heat capacity of the stem,  $k_r$  and  $k_z$  are the thermal conductivities in the radial ( $r$ ) and axial ( $z$ ) directions, respectively,  $T$  is the temperature,  $Q$  is the sap flow rate,  $c_w$  is the specific heat capacity of water and  $P$  is the heat generated by the source.

The three-dimensional heat transport problem can be reduced to axisymmetric heat conduction and convection problem if we assume no external short wave radiation impact on the sensors (Baker and Nieber 1989, Groot and

King 1992). If we further assume that sap-flow is in the axial direction only, the problem is simplified into axial and radial conduction and axial convection (Baker and Nieber 1989).

In this study, for the sake of simplicity, the temperature profiles are regarded as being in a steady state at any time. This means that the radial as well as the axial profiles follow the stationary logarithmic and linear laws of heat conduction (e.g. Alonso and Finn 1977) during each time step of the numerical model. Changes in profiles are only due to changing boundary conditions, i.e. due to changes in the system after each time step resulting from the changes in the environment or sap flow rates. This kind of approach is considered to be quasistationary and it predicts well the system dynamics, if the relaxation times for establishing stable temperature and flow profiles are much shorter than the typical times during which the physical state of the system is changing. The relaxation time for the case of pure conduction depends on the characteristic size of the system and thermal diffusivity. For a tree stem, the relaxation time can be several hours but the presence of convection (sap flow) reduces it significantly. If the relaxation time is long, the quasistationary model tends to underestimate the response of the system for the changing ambient conditions and the results are conservative estimates. For steady-state conditions, the method gives correct solutions. For a treatment of non-stationary heat transport in a stem, we refer, e.g., to Groot and King (1992).

The quasistationary solution of the problem can be solved by discretizing the studied object into volume elements and integrating their individual heat fluxes. In this way the problem is easily solvable with commercial simulation packages.

Our model simulates (1) the propagation of heat energy in stem sections (caused by conduction and convection with prescribed input sap flow  $Q_p$ ), and (2) the calculation of sap flow rate  $Q_{SHB}$  according to the principles of the heat balance method of the Flow32™ Stem-Flow Gauge (Dynamax Inc.) (Sakuratani 1981, Dynamax 1990). The simulated system consists of a piece of tree stem, a heater band wrapped around it and a thermal insulation cover enclosing

them. The heater element heats the system with constant power. The heat energy is conducted radially in the system and propagates vertically by conduction and convection with the stem sap flow.

### Simulating the propagation of heat in the stem segment

The modelled piece of tree stem is divided radially ( $r$ ) into ten coaxial rings of constant width and vertically ( $z$ ) into twenty slices. The heater element and the insulation cover are also divided into pieces. The attributes of each such defined element ( $r, z$ ) are: physical dimensions, mass, amount of water, thermal conductivity and heat capacity. The state variable of an element is heat energy, which is transformed into temperature by using the heat capacity and mass of an element. For each element ( $r, z$ ) we can then write:

$$c_{r,z} m_{r,z} \frac{dT_{r,z}}{dt} = 2\pi l_z k_r \left[ \left( \frac{T_{r-1,z} - T_{r,z}}{\ln(r/r_{r-1})} \right) - \left( \frac{T_{r,z} - T_{r+1,z}}{\ln(r_{r+1}/r)} \right) \right] + \frac{k_z A_{r,z}}{l_z} [(T_{r,z-1} - T_{r,z}) - (T_{r,z} - T_{r,z+1})] + Q_{p,r} c_w (T_{r,z-1} - T_{r,z}) + P_{r,z} \quad (2)$$

where  $c_{r,z}$  is the heat capacity,  $m_{r,z}$  is the mass of an element,  $k_z$  and  $k_r$  are the thermal conductivities of the material in axial and radial directions, respectively,  $A$  is the basal area of a cylinder,  $T_{r,z}$  is the temperature,  $l_z$  is the height and  $r_r$  is the radius of a cylinder,  $Q_{p,r}$  is the input sap flow,  $c_w$  is the heat capacity of water, and  $P_{r,z}$  is the heating power for heated elements. In each term of conduction and convection the first term describes the input into the element and the second the output from the element (*see also* Fig. 1).

The heat capacity of a stem element is

$$c = \frac{c_w \rho_w + c_{dw} \rho_{dw}}{\rho_w + \rho_{dw}} \quad (3)$$

where  $c_w$  is the heat capacity of water,  $\rho_w$  the density of water in an element,  $c_{dw}$  and  $\rho_{dw}$  are those of dry wood, respectively.

The heater elements are heated by constant

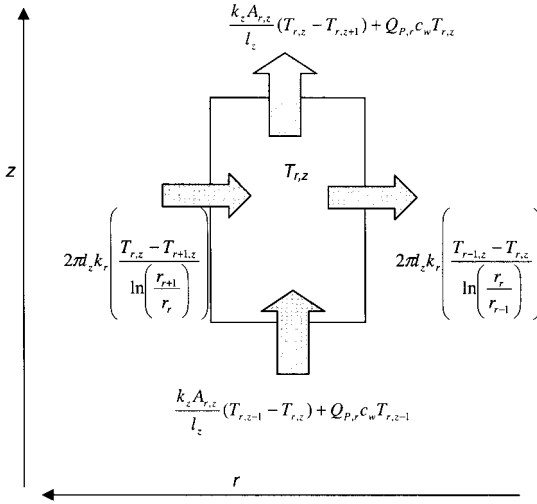

**Fig. 1.** A schematic flow diagram of one stem element ( $r, z$ ).  $T_{r,z}$  is the temperature of the element. The arrows represent the vertical and horizontal energy fluxes. The horizontal fluxes contain the conductive flow only. The vertical fluxes contain both conductive and convective components. The elements at the surface of the stem also contain, in the radial direction, the heat flux  $P_{in}$  from the heating element and the heat loss outside the system  $q_l$ .

power  $P_{in}/n$ , where  $P_{in}$  is the total heating power used and  $n$  is the number of heated elements. Radial heat flux from the outermost cylinder to ambient air is estimated with sensible heat loss as:

$$q_l = \frac{1}{R_{bl}} (T_{r_{max},z} - T_a) \quad (4)$$

where  $R_{bl}$  is the boundary layer resistance for heat conduction,  $T_{r_{max},z}$  is the temperature of the insulation cover and  $T_a$  is the ambient temperature. A schematic representation of the modelled system is presented in Figs. 1 and 2.

### Estimation of sap flow using the SHB-method

The model also simulates the Dynamax sap flow gauge by calculating the sap flow from the simulated temperature gradients (Eqs. 2–4) at the positions of the temperature sensors of the

gauge as input and the equations proposed by the manufacturer. Fig. 3 shows a schematic illustration of the Dynamax system. The equations are presented in Appendix.

The heat balance method utilized by Dyna-gage' assumes steady-state conditions and thus ignores the change in heat storage in the stem. In numerous studies (Valancogne and Granier 1991, Shackel *et al.* 1992) it has been proposed that the heat storage term  $Q_s$  can be included in the heat balance equation (Eq. 10 in Appendix) to give improved results

$$Q_s = cm \frac{dT}{dt} \quad (5)$$

where  $dT/dt$  is the temperature rise of the heated segment,  $c$  and  $m$  the heat capacity and mass of the segment, respectively. In our model the storage term is the sum of the time derivatives of heat energy  $E$  of the heated segments

$$Q_s = \sum_r \sum_z \frac{dE}{dt} \quad (6)$$

### Boundary conditions, parameters and model implementation

The model boundary conditions are time dependent values of prescribed sap flow  $Q_p(t)$ , ambient temperature  $T_a(t)$  and sap temperature entering the tree  $T_w(t)$ . The model parameters are presented in Table 1. The model has been implemented with Powersim<sup>TM</sup> simulation software (Powersim AS, Norway).

### Material and methods

#### Experimental design and measurements

We focused the numerical analyses to study the factors that influence the sap-flow estimation of young coniferous trees in field conditions. We measured sap flow at the Helsinki University SMEAR II Station at Hyytiälä in southern Finland (61°51'N, 24°17'E, 181 m a.s.l.) (Vesala *et*

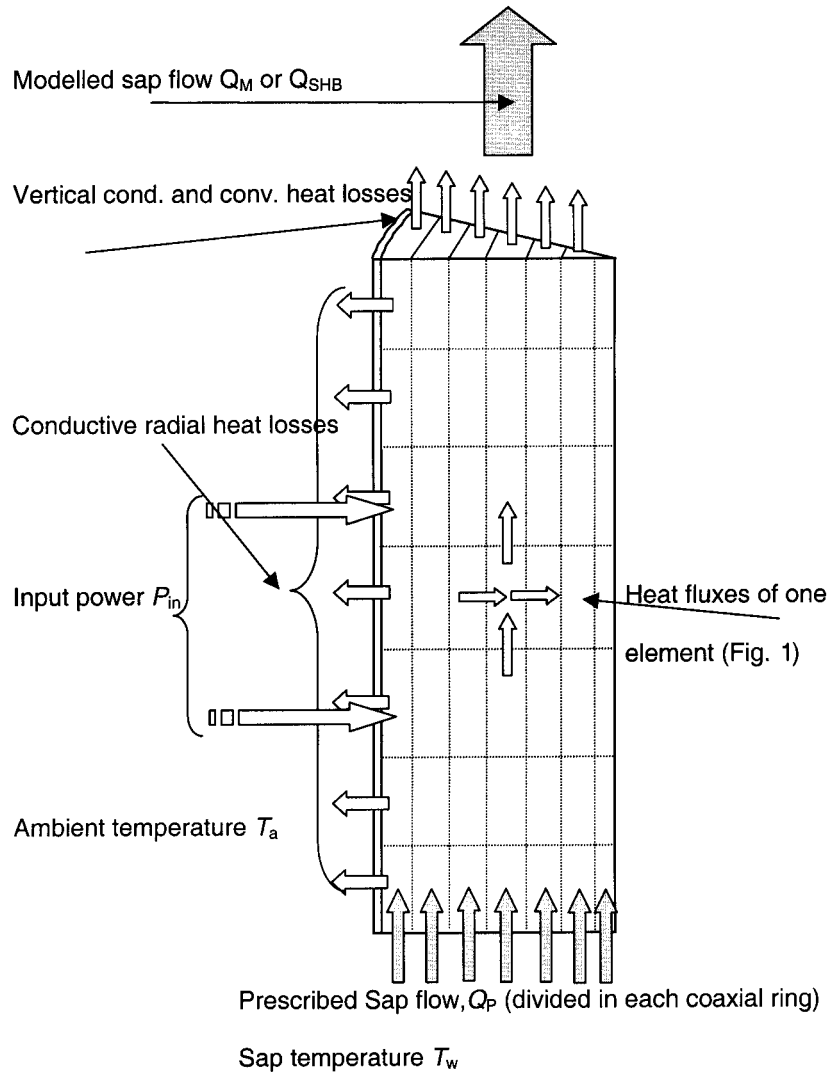

**Fig. 2.** A schematic illustration of the simulated system.

*al.* 1998) using the Dynamax Flow32™ system. For testing the model, we measured sap flow at the crown base of a lower canopy Scots pine (*Pinus sylvestris* L.) tree (diam. 55 mm) and an understorey mountain ash (*Sorbus aucuparia* L.) (diam. 12 mm), both growing in a 35-year-old stand in moderately fertile soil (*Vaccinium* type, Finnish site type classification). The average height and diameter of the trees is 12 m and 13 cm respectively, and the number of stems is 2500 per hectare.

The Dynamax gauges (SGB 50 and SGB 19) were installed according to the procedure recom-

mended by the manufacturer (Dynamax 1990). The stem surface was smoothed and a thin layer of silicone grease was applied on the surface of the stem before installing the gauges and the radiation shields. The stem diameters were selected so that they remained well within the dimensions recommended by the manufacturer. The gauges were fitted tightly against the stem but excessive pressure was avoided. During earlier studies we had observed damage to stems similar to those reported by Grime *et al.* (1995a). Although the damage has been attributed to the silicon grease disturbing normal bark

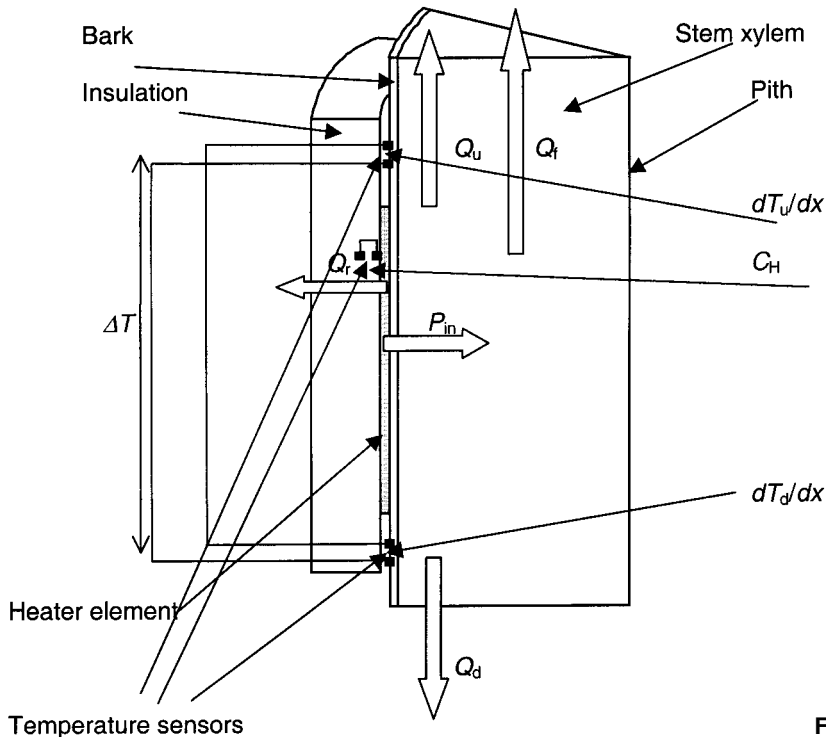

Fig. 3. Dynagage schematics.

respiration (Grime and Sinclair 1999), our observations would tend to suggest that very tight fitting of the sensors and large temperature increases during low flow conditions may also contribute to the problem. Because of these reasons, we also had the heating power on a moderate setting, within the range suggested by the manufacturer, carefully trying to avoid excessive heating during slow flow conditions. In addition, we inserted an extra thermoelement into the centre of the heated sector of the Scots pine stem.

As a reference, we simultaneously moni-

tores transpiration from the top shoots of the Scots pine tree with an automatically operating gas-exchange chamber. See Vesala et al. (1998) for a detailed description of the measurements at the station.

### Model evaluation

The model was evaluated by comparing the model output  $Q_M$  to the prescribed sap flow  $Q_P$ .  $Q_M$  was calculated with the SHB method (equations in Appendix), but by using the sum of

**Table 1.** Parameters of the model

Symbol	Description	Value
$c_w$	Heat capacity of water	4.186 kJ kg <sup>-1</sup> °C <sup>-1</sup>
$r_w$	Water density in an element	650 kg m <sup>-3</sup>
$c_{dw}$	Heat capacity of dry wood	0.4 J kg <sup>-1</sup> °C <sup>-1</sup>
$r_{dw}$	Density of dry wood	400 kg m <sup>-3</sup>
$R_{bl}$	Boundary layer resistance for heat conduction	0.3 K W <sup>-1</sup> *)

\*) T. Vesala pers. comm.

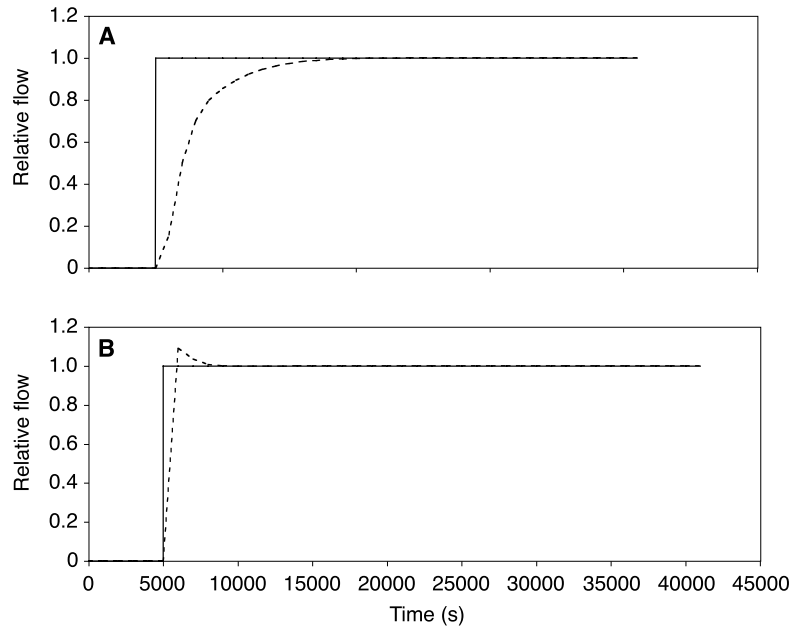

**Fig. 4.** Model evaluation: Prescribed (solid line) and simulated (dotted line) relative sap flow without storage term (**A**) and with storage term (**B**).

vertical conductive heat losses of each simulated coaxial ring at the stem segment boundary instead of  $Q_v$ , and the sum of radial conductive heat losses of each simulated slice at the surface of the stem instead of  $Q_r$  (see Fig. 2 and Appendix).

## Results and discussion

### Results from model evaluation

In steady state, the  $Q_M$  deviated less than 0.3% from the prescribed flow  $Q_P$  (Fig. 4A). When the heat storage term is included in calculations, the flow calculated from the whole segment heat balance closely followed the step change, with the exception of the initial overestimate of flow (Fig. 4B). This small deviation from the prescribed flow may indicate transient problems resulting from the assumption of quasistationarity.

### Effect of stem diameter and sap flow velocity

Figure 5 presents the estimated sap flow,  $Q_{SHB}$ ,

according to the Dynamax-SHB method after a step change in sap flow for two different stem diameters and flow velocities. The higher flow velocity equals that often observed at our measuring site in southern Finland during mid-summer (data not shown) and the lower flow velocity is half of the higher one. The sap flow velocity was kept constant over the whole woody cross-sectional area. The rates of input power used in the simulations were comparable with those recommended for Dynamax gauges of similar sizes. As is apparent from Fig. 5, large flow rates result in an underestimate of the real rate and the increasing stem size will magnify the underestimate even more. The reason for this in the case of bigger stems is biased estimation of the temperature increase caused by heating  $\Delta T$  (see Fig. 3) when measured on the surface of the stem. Steady-state temperature distributions inside the stem section are presented in Fig. 6 (bigger stem and higher flow velocity in Fig. 6A, smaller stem and lower flow velocity in Fig. 6B). In Fig. 6A, in particular, the temperature distribution clearly deviates from the underlying assumption of a radially homogeneous temperature field, which the Dynamax SHB method uses.

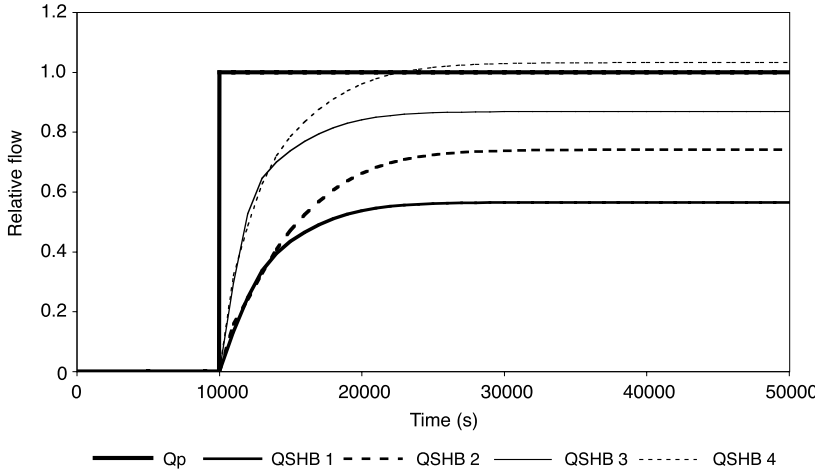

**Fig. 5.** Simulated SHB method sap flows (relative to prescribed flow).  $Q_{SHB1}$ : stem diam. 55 mm, higher flow velocity,  $Q_{SHB2}$ : stem diam. 55 mm, lower flow velocity,  $Q_{SHB3}$ : stem diam. 27.5 mm, higher velocity,  $Q_{SHB4}$ : stem diam. 27.5 mm, lower flow velocity.  $Q_p$  is the prescribed sap flow.

### Effect of input power

The manufacturer recommends that the heater power should be adjusted to maximize the proportion of heat carried by the sap stream since the input power and the temperature difference between entering and leaving sap are measured directly, with consequently smaller errors in their estimation (Grime and Sinclair 1999). However, even if the power input could influence the proportion of heat carried by the sap stream, it cannot improve the accuracy of determining the real temperature of the sap flow leaving the measured segment. Consider the steady state situation close to the centre of the stem at the heated part of the trunk. The heat carried there by conduction equals (approximately, with a high flow rate) the heat carried out by convection i.e.:

$$k \frac{T_0 - T_i}{\ln(r_0/r_i)}$$

giving

$$T_i = \frac{\frac{k}{\ln(r_0/r_i)} T_0}{Q + \frac{k}{\ln(r_0/r_i)}} \quad (7)$$

where  $r_0$  is the radius of the stem,  $r_i$  the radius of the position close to the centre of the stem,  $T_0$  is the temperature under the heater and  $T_i$  the

temperature close to the centre of the stem,  $k$  is the thermal conductivity of wood and  $Q$  is the flow rate. It can be understood from Eq. 7 that the internal and surface temperatures are linearly related and doubling the surface temperature will also double the temperature in the centre. Equation 7 also shows that the resulting temperature gradient depends on the heat conductivity and flow velocity. In no flow conditions at steady state there is no radial temperature gradient, but as flow increases, the gradient increases inversely proportionally to the flow rate. As the thermal conductivity between the centre and the surface increases, as is the case when the stem diameter decreases, the axial temperature gradient also decreases with the same flow velocity. Thus, for smaller stems the assumption of a homogeneous axial temperature field is more justified. Also, as Fig. 6 demonstrates, as the distance from the heater decreases, the radial gradient rapidly decreases.

### Effect of flow depth

If the sap flow occurs only in the superficial wood layer of the stem, it could be expected, based on the above discussion, that temperature measurements on the wood surface would give a sufficiently good estimate of the temperature difference between sap entering and that leaving the measured segment. We simulated a sap flow similar to the previous simulated flow in the



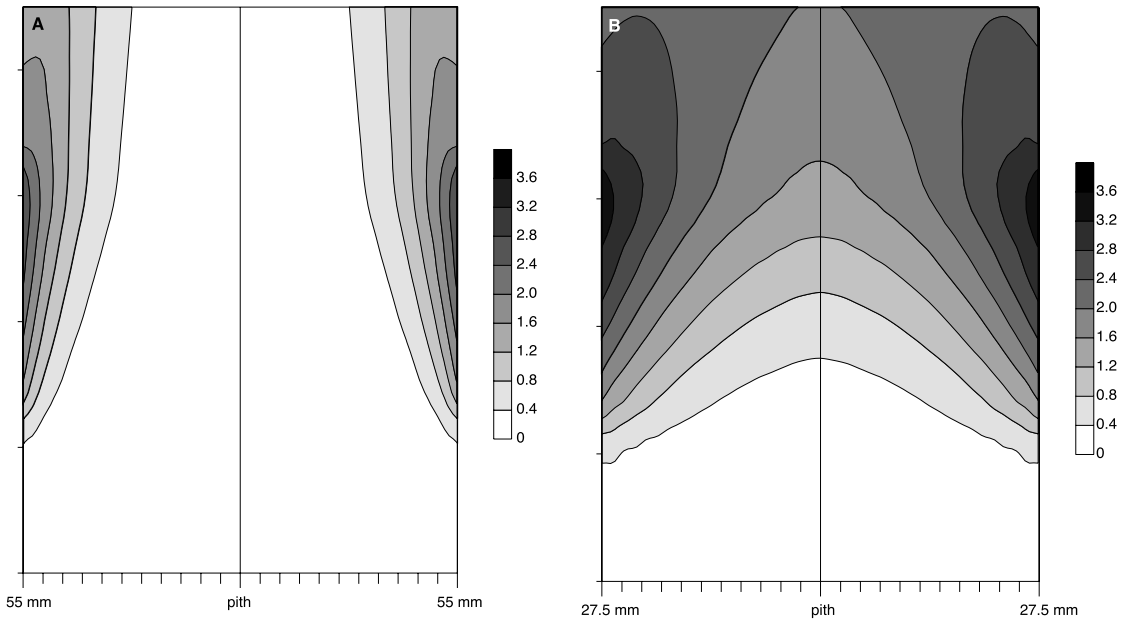

**Fig. 6.** Temperature distributions inside the stem segment at steady state. Stem diameter 55 mm and higher sap flow velocity (A) Stem diameter 27.5 mm and lower flow velocity (B).

bigger stem (diam. 55 mm), but this time assuming flow in the outermost wooden cylinder of the stem only. The simulated flow is presented in Fig. 7A and temperature distribution in Fig. 7B. In this case, the temperature increase across the segment,  $\Delta T$ , measured on the surface is a better estimator of the actual temperature increase of the whole segment, resulting in a good prediction of the sap flow at a steady state. However, it is notable that the large internal and non water-conducting mass acts as a large heat storage, influencing the transient dynamics of the method. The system reaches the steady state condition much later than previously, and the time dynamics is also different (Figs. 5 and 7A).

### Simulations versus field measurements

Figure 8A presents the daily dynamics of transpiration from one gas-exchange chamber at the top of the Scots pine tree in non-shaded conditions for a period of three days in early June 1999. Panels B and C in Fig. 8 present the whole canopy transpiration from the Dynamax measurements for the dominant Scots pine tree and

the understory mountain ash tree for the same period. The measurements are not directly comparable but qualitative. Water vapour concentration and air temperature inside the canopy were measured at several heights (Vesala *et al.* 1998) and no significant variation was found in VPD (data not shown) due to daytime turbulent mixing. The patterns of the mountain ash sap flow and the transpiration measurement are similar, although the sap flow measurement remains at a lower level during the morning hours. The Scots pine measurement displays large peaks, which are clearly unrealistic since similar behaviour is not observed in the simultaneous transpiration measurements.

We used the numerical model to imitate similar sap flow conditions and measurements with Dynamax. Since our quasistationary approach responds more slowly than the real systems to the changes, the simulations need to be viewed as qualitative estimations of the system behaviour. Figure 9 presents the time variation in the boundary conditions. After sunrise the prescribed sap-flow increased rapidly to a maximum value that remained constant during the day and decreased gradually to zero in the late

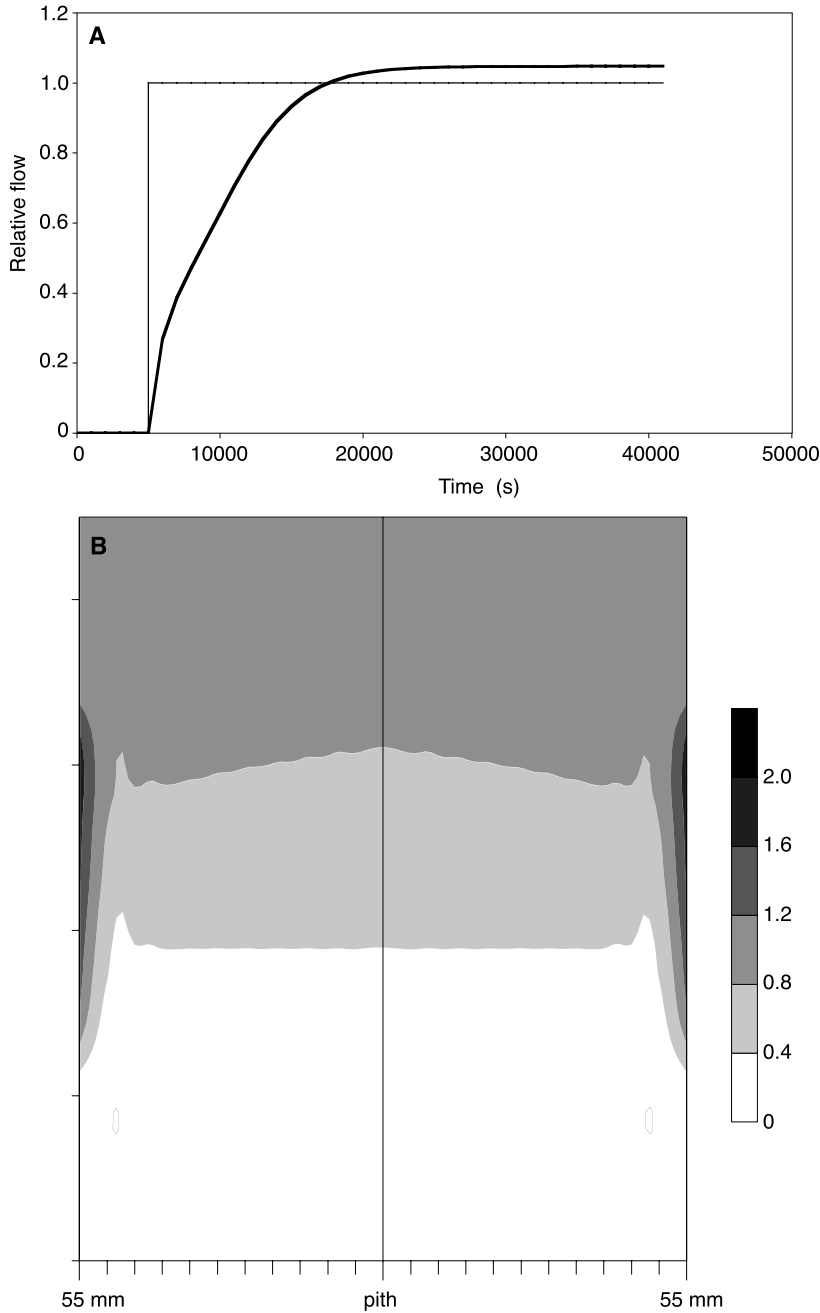
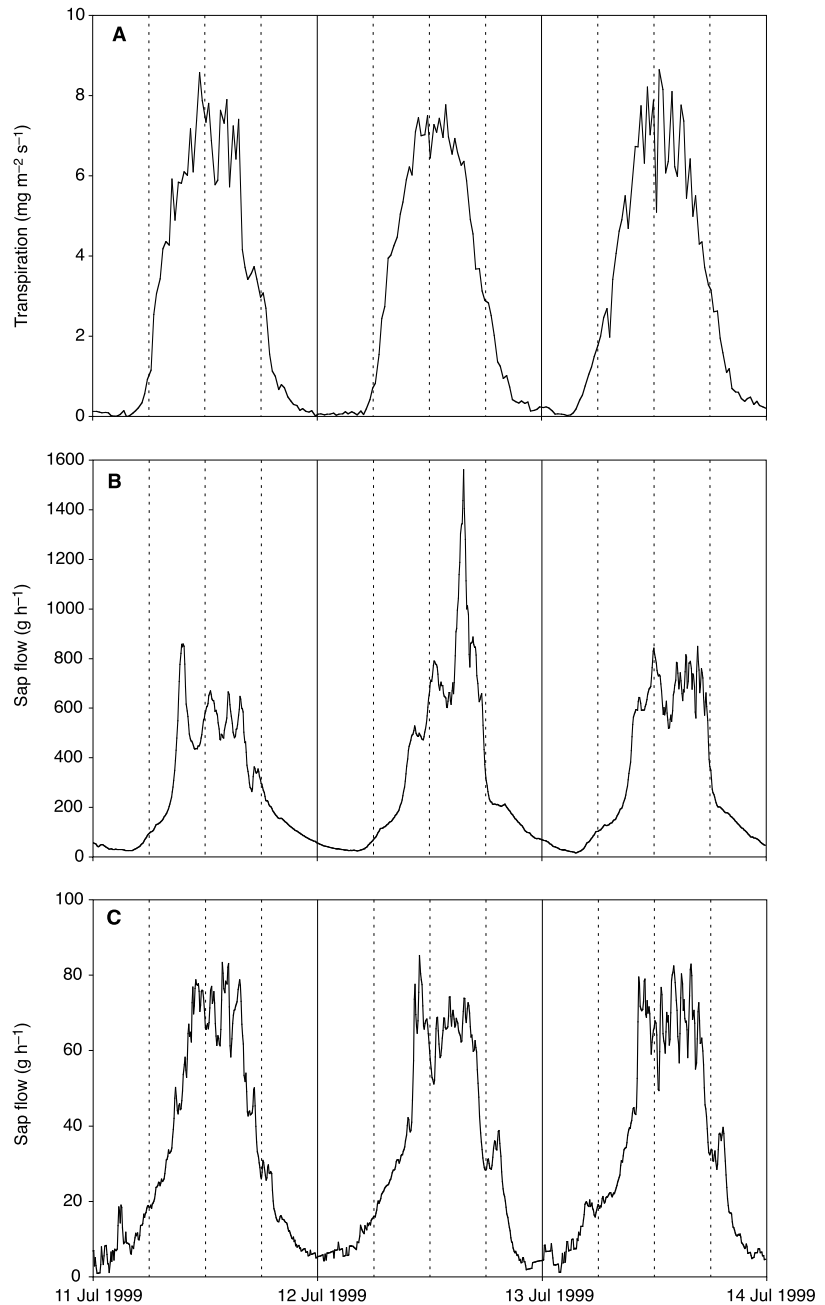

**Fig. 7.** Prescribed (thin line) and simulated (thick line) sap flow (A) and temperature distribution in the stem segment (B). Flow at the superficial wood layer of the stem only.

evening. There was similar variation in the ambient temperature with an observed amplitude of 15 °C. The sap temperature entering the gauge was assumed to follow the air temperature, with a time lag of about two hours in the morning.

The prescribed sap flow (thin line) and the

simulated sap flow (thick line) are presented in Fig. 10. The simulated flow shows large and unrealistic peaks similar to the field measurement (Fig. 8B). Both the simulated (Fig. 11A) and measured (Fig. 11B) values of the radial temperature gradient ( $C_H$ ) and the simulated (Fig. 11C) and measured (Fig. 11D) temperature increase



**Fig. 8.** Transpiration measured from the top shoot with the gas exchange chamber method (A) and measured sap flow at the crown base (B) of a lower canopy Scots pine. Measured sap flow of an understory mountain ash (C).

over the heated segment ( $\Delta T$ ) varied over the course of a day (Fig. 11). Even if no exact match between the values was attempted, it is clear that the pattern is very similar, both in the measurements and in the simulations and as reported earlier (Grime *et al.* 1995b). As the flow starts in the morning, the heated water moves upwards,

increasing the  $\Delta T$  value, followed by a substantial drop in the value as the flow increases and the heating is no longer sufficient to maintain the same temperature. At some stage, as the air warms faster than the sap, the direction of heat flux between the gauge and the ambient reverses, giving rise to large overestimates of sap flow. The

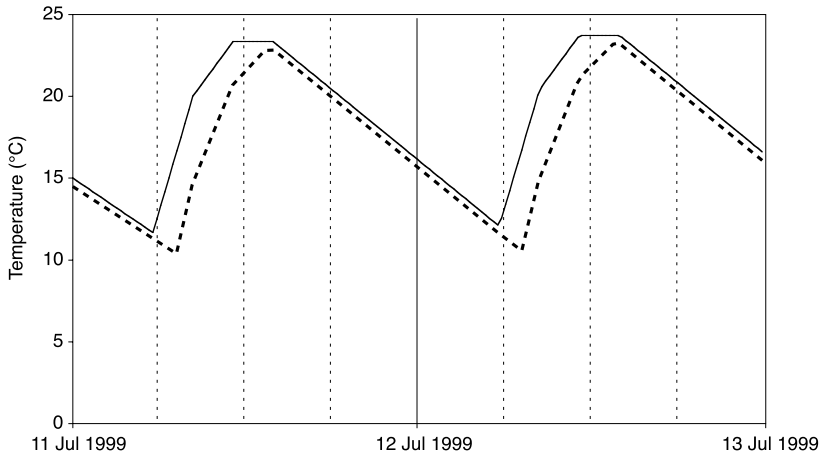

**Fig. 9.** Prescribed air (solid line) and sap (dotted line) temperatures that simulate the measuring conditions.

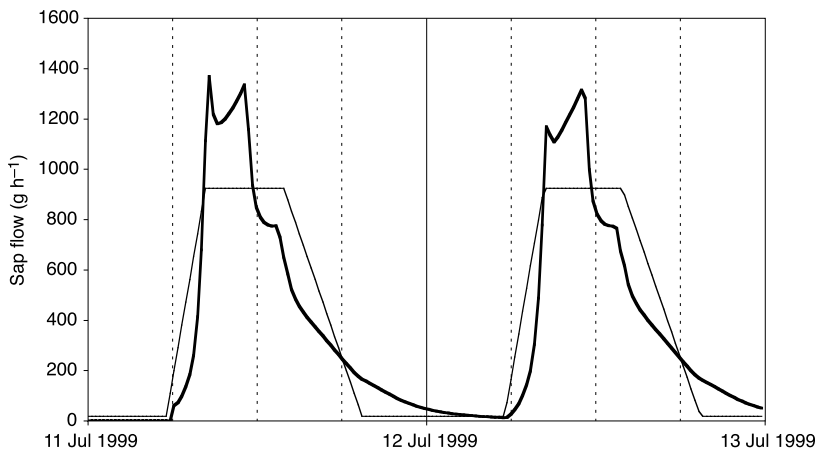

**Fig. 10.** Prescribed (thin line) and model simulated (thick line) sap flow at simulated measuring conditions.

weather giving rise to this type of situation is very common in southern Finland, especially during the early summer when the night and daytime temperatures may differ by more than 20 °C. It is interesting that this does not seem to be a problem for smaller segments. Most likely they are so much better coupled with the atmospheric temperature that similar, substantial variation between the sap entering the measured area and the ambient air does not develop.

The early morning reversal of heat flow from the gauge can be corrected by increasing the power supplied to the heater. This also increases the value of  $\Delta T$ , making the sap flow estimates less sensitive to small variation and possible erroneous measurements in the other components of the underlying heat balance equation (see Appendix). This is reflected in the better

behaving measurement of sap flow (Fig. 12). However, the problems associated with the uneven temperature distribution in the segment are reflected in the systematic underestimate of the sap flow as discussed above.

## Concluding remarks

The literature contains a large amount of analyses of the SHB sap flow method. The method has been proposed for medium to small sized stems (e.g. Grime *et al.* 1995a). Although Dynamax Inc. offers commercial stem gauges up to 120 mm-sized stems, most of the analyses of the functioning of the method have concentrated on considerably smaller stem sizes ( $\pm 20$  mm max.) (Grime *et al.* 1995a, Groot and King 1992,

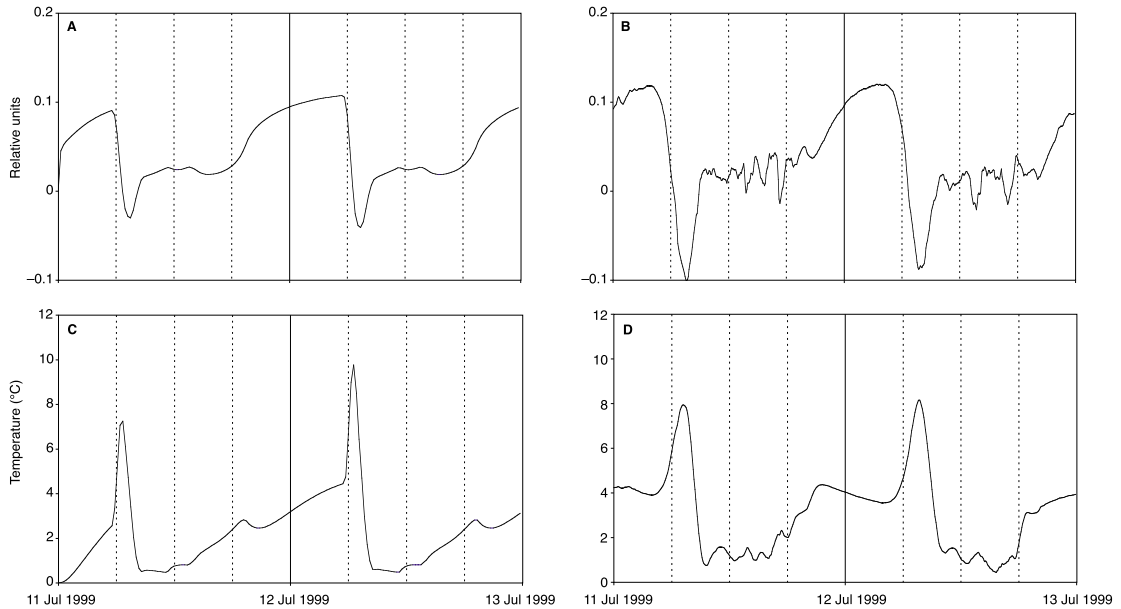

**Fig. 11.** Simulated (A) and measured (B) radial temperature gradient (relative units). Simulated (C) and measured (D) temperature increase  $\Delta T$  over the heated segment of stem.

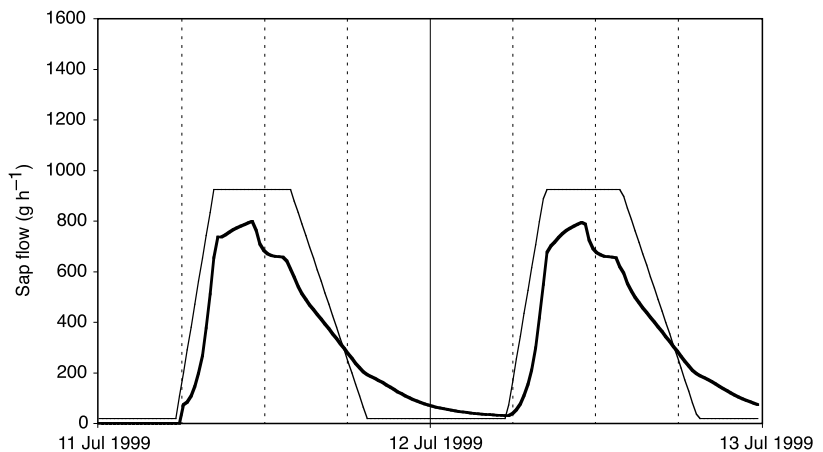

**Fig. 12.** Prescribed (thin line) and simulated sap flow with increased heating power.

Baker and Nieber 1989). The method seems to work satisfactorily for these sizes even though it seems that this is often a result of various deviations from the basic assumption cancelling each other (Baker and Nieber 1989). Shackel *et al.* (1992), however, wrote a strong critique on the method when it was used on only 60 mm. sized stems. Grime and Sinclair (1999) also came to the conclusion that the method was problematic with 35 mm. stems. In our numerical analyses we concentrated on studying the

performance of the method on mid-sized (20–60 mm) coniferous stems, comparing the modelled heat fluxes with simulated Dynamax performance, and comparing these with our experiences in the field.

Baker and Nieber (1989) and Groot and King (1992) pointed out problems that are associated with a non-homogeneous temperature field when the measurements of the heat balance are conducted from the surface of the studied object. Our simulations highlighted the problem,

especially for large objects whose sap flows in deep layers as well. As the size of the segment increases, the radial temperature difference between the surface and the middle section of the segment increases, leading to erroneous measurements. Thus in large segments, higher flow rate causes significant deviation from the homogeneous temperature field assumption. One way to avoid the problem would be to measure the temperature from various distances above the heater or to insert some temperature sensors inside the xylem. This could help to increase the accuracy of the system.

As Grime and Sinclair (1999) discussed, and as recommended by the manufacturer (Dynamax 1990), the power input could be used to influence the proportional amount of heat carried by the sap under given flow conditions. However, as our analyses showed, power input does not influence this. Increasing the power input will remove the problem of non-controlled heat flux from outside into the system and make the system less sensitive to small changes in the variation of the different components of heat balance by increasing the value of  $\Delta T$ . However, increased input power does not solve the problem of an inaccurate picture of the real temperature difference between the sap entering and leaving in large trees with deep sap flow, if surface temperatures are measured only.

Our analysis showed that the SHB-method gives reasonable estimations of steady state sap flow, even for large stems with superficial sap flow. Baker and Nieber (1989) also pointed out that the system performance was better in dicotyledons than in monocotyledons. However, in large segments, the big, non water-conducting internal part of the stem acts as a substantial heat storage and is certain to influence the time response of the method. This can be appreciated from the step change simulations but its full evaluation in varying environments is not possible with our model.

The transient behaviour of the heat balance method has been identified as one of the major problems of the method (Groot and King 1992). This is very obvious in our simulations imitating system behaviour in field conditions. The combined effect of sap temperature lagging behind

air temperature, and large flow rate may cause substantial morning peaks in the sap flow estimates (*see also* Grime et al. 1995a). Adjusting the power input and including the storage term into the heat balance equation will improve the situation. However, accurate estimation of the whole stem temperature may be problematic in large stems because during the flow a temperature gradient quickly develops in the stem.

If sap flow is measured in large segments with the SHB method, it is obvious that a better method of estimating the influence of the developing temperature gradient within the stem is required. Since the temperature difference between the leaving and entering sap is used to derive the sap flow from the estimate of heat carried by sap flow, it is clear that wrong estimates of this difference have a substantial effect on the flow estimate. As our analyses showed, this value depends on the size and flow rate of the segment, so its impact becomes more significant as larger segments are analysed. Temperature measurements from inside the wood would improve the accuracy of the system.

## References

- Alonso M. & Finn E.J. 1977. *Fundamental university physics Vol. II*, Addison-Wesley, Reading, Massachusetts, 965 pp.
- Baker B.L. & Nieber J.L. 1989. An analysis of the steady-state heat balance method for measuring sap flow in plants. *Agric. For. Met.* 48: 93–109.
- Cermak J., Kucera J. & Penka M. 1976. Improvement of the method of sap flow rate determination in full-grown trees based on heat balance with direct electric heating of xylem. *Oecologica*, 64: 145–151.
- Dugas W.A., Wallace J.S., Allen S.J. & Roberts J.M. 1993. Heat balance, porometer, and deuterium estimates of transpiration from potted trees. *Agric. For. Met.* 64: 47–62.
- Dynamax 1990. *Dynagage™ installation and operation manual*. Dynamax, Houston, TX, USA. 80 pp.
- Granier A. 1985. Une nouvelle méthode pour la mesure du flux de sève brute dans le tronc des arbres. *Ann. Sci. For.* 42: 193–200.
- Grime V.L., Morrison J.I.L. & Simmonds L.P. 1995a. Including the heat storage term in sap flow measurements with the heat balance method. *Agric. For. Met.* 74: 1–25.
- Grime V.L., Morrison J.I.L. & Simmonds L.P. 1995b. Sap flow measurements from stem heat balances: A com-

- parison of constant with variable power methods. *Agric. For. Met.* 74: 27–40.
- Grime V.L. & Sinclair F.L. 1999. Sources of error in stem heat balance sap flow measurements. *Agric. For. Met.* 94: 103–121.
- Groot A. & King, K.M. 1992. Measurement of sap flow by the heat balance method: numerical analysis and application to coniferous seedlings *Agric. For. Met.* 59: 289–308.
- Hari P., Keronen P., Bäck J., Altimir N., Linkosalo T., Pohja T., Kulmala, M. & Vesala, T. 1999. An improvement of the method for calibrating measurements of photosynthetic CO<sub>2</sub> flux. *Plant Cell Environ.* 22: 1297–1302
- Hinckley T.M., Brooks J.R., Cermak J., Ceulemans R., Kucera J., Meinzer F.C. & Roberts D.A. 1994. Water flux in a poplar stand. *Tree Physiol.* 14: 1005–1018.
- Irvine J. & Grace J. 1997. Continuous measurement of water tensions in the xylem of trees based on the elastic properties of wood. *Planta* 202: 455–461.
- Jones H.G., Hames P.C.J. & Higgs K.H. 1988. Evaluation of various heat pulse methods for estimation of sap flow in orchard trees: comparison with micrometeorological estimates of transpiration. *Trees* 2: 250–260.
- Nikinmaa E., Kaipainen L., Mäkinen M., Ross J. & Sasonova, T. 1996. Geographical variation in the regularities of woody structure and water transport. *Acta For. Fenn.* 254: 49–78.
- Rannik Ü. 1998. Turbulent atmosphere: Vertical fluxes above a forest and particle growth. Ph.D. Thesis. *Report Series in Aerosol Science* 35.
- Sakuratani T. 1981. A heat balance method for measuring water flux in the stem of intact plants. *J. Agric. Meteorol.* (Japan) 34: 177–187.
- Sevanto S., Vesala T., Perämäki M., Pumpanen J., Ilvesniemi H. & Nikinmaa E. 2001. Xylem diameter changes as an indicator of stand-level evapo-transpiration. *Boreal Env. Res.* 6: 45–52.
- Shackel K.A., Johnson R.S., Medawar C.K. & Phene C.J. 1992. Substantial errors in estimates of sap flow using the heat balance technique on woody stems under field conditions. *Am. J. Hortic. Sci.* 117: 351–356.
- Valancogne C. & Granier A. 1991. Intérêt des méthodes thermiques de mesure du flux de sève pour l'étude du bilan hydrique des savanes. *IAHS Publ.* 199.
- Valancogne C. & Nasr Z. 1989. Measuring sap flow in the stem of small trees by a heat balance method. *Hort-science* 24: 383–385.
- Vesala T., Haataja J., Aalto P., Altimir N., Buzorius G., Garam E., Hämeri K., Ilvesniemi H., Jokinen V., Keronen P., Lahti T., Markkanen T., Mäkelä J.M., Nikinmaa E., Palmroth S., Palva L., Pohja T., Pumpanen J., Rannik Ü, Siivola E., Ylitalo H., Hari P. & Kulmala M. 1998. Long-term field measurements of atmosphere-surface interactions in boreal forest combining forest ecology, micrometeorology, aerosol physics and atmospheric chemistry. *Trends Heat Mass Moment. Transf.* 4: 17–35.

**Appendix.** Equations used for calculating the sap flow  $Q_{SHB}$  are (Dynamax 1990):

$$P_{in} = Q_r + Q_v + Q_f \quad (8)$$

$$Q_r = K_{sh} C_H \quad (9)$$

$$Q_v = Q_u + Q_d \quad (10)$$

$$Q_u = kA \frac{dT_u}{dx} \quad (11)$$

$$Q_d = kA \frac{dT_d}{dx} \quad (12)$$

$$Q_{SHB} = \frac{Q_f}{c_w \Delta T} \quad (13)$$

$P_{in}$  is the heating power,  $Q_r$  is the radial heat flux conducted through the gauge,  $K_{sh}$  is the thermal conductance constant of the gauge,  $C_H$  is the radial temperature gradient,  $Q_v$  is the vertical conductive heat flux having components  $Q_u$  and  $Q_d$ ,  $k$  is the thermal conductivity of water saturated wood,  $A$  is the stem cross-sectional area,  $Q_f$  is the heat convection carried by the sap,  $c_w$  is the heat capacity of water,  $\Delta T$  is the temperature increase of the sap,  $dT_u/dx$  and  $dT_d/dx$  are the temperature gradients upwards and downwards on the surface of the stem, (Fig. 3) and  $Q_{SHB}$  is the estimated sap flow.